

# INSTALLATION, OPERATION AND MAINTENANCE INSTRUCTIONS

## Acclaim - Recessed Light Emitting Diode (LED) Luminaires

### Industrial

**Important:** Please read these instructions carefully before installing or maintaining this equipment. Good electrical practices should be followed at all times and this data should be used as a guide only.

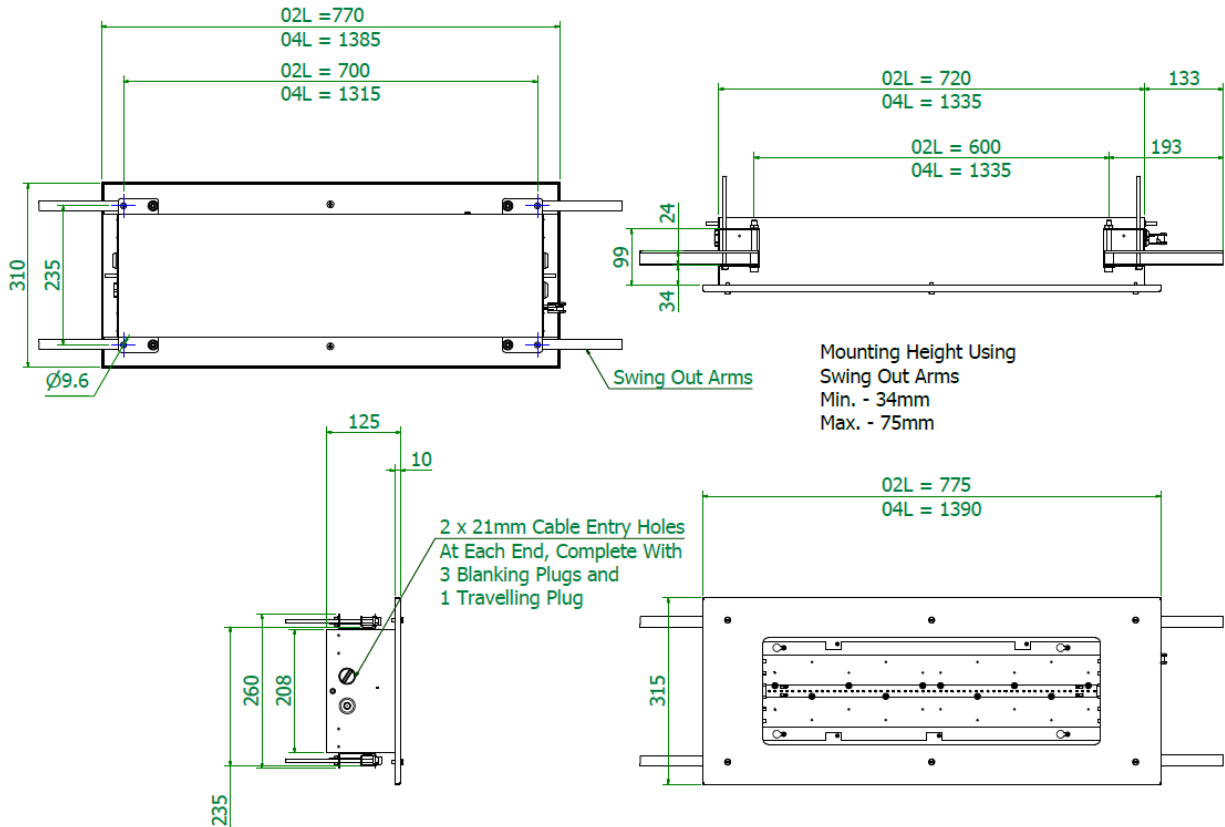

#### SOLID CEILING TYPE

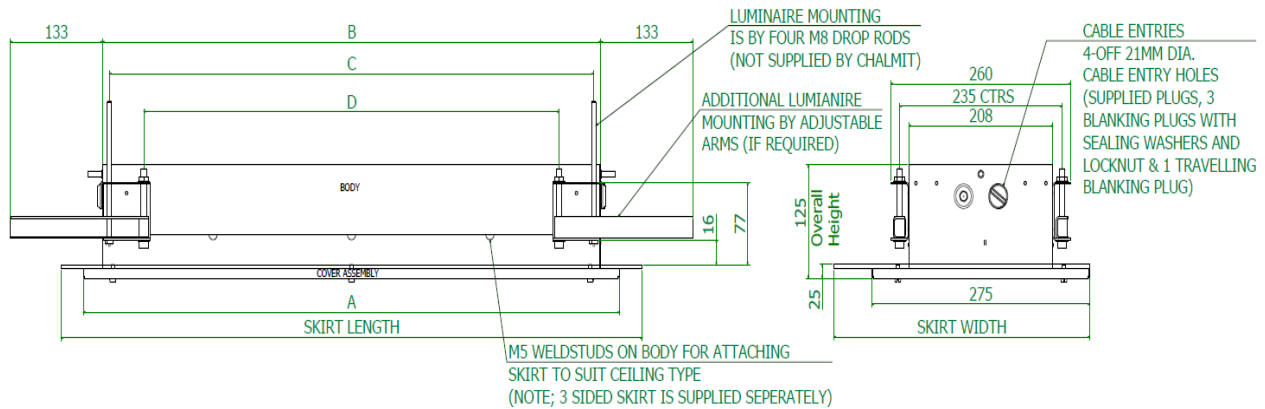

**M300 PLANK CEILING TYPE**



Model	A	B	C	D	Skirt Length	Skirt Width	Cut Out Size
02L	750	720	700	600	820	309	800 (L) x M300 TILE WIDTH
04L	1365	1335	1315	1215	1435	309	1415 (L) x M300 TILE WIDTH

0.0 Specification	
Type of Protection	N/A
Standards	EN 60598-1, EN 60598-2-22
Area Classification	Industrial, (Non- Hazardous)
Ambient	-20°C to 45°C
Ingress Protection	IP54 to EN 60529
  	<p>The CE marking of this product applies to "The Electrical Equipment (Safety) Regulations 2006", "The Electromagnetic Compatibility Regulations 2004", the "Waste Electrical and Electronic Equipment Regulations 2006". [This legislation is the equivalent in UK law of EU directives 2014/35/EU, 2014/30/EU, 2012/19/EU respectively].</p> <p>The UKCA marking of this product applies to "The Electrical Equipment (Safety) Regulations 2016", "The Electromagnetic Compatibility Regulations 2016", the "Waste Electrical and Electronic Equipment Regulations 2012</p> <p>M Poutney Technical Manager</p>

Ratings – High Frequency Control Gear.

Non-Emergency:

No. of LED's	Lumens	Driver Current	Power Consumption Watts	Line Current	Inrush Current/ Duration
1	1632	700mA	20	0.10 – 0.09A	6A (45 us)
4	4035	400mA	42	0.20 – 0.19A	5A (20us)
<b>Emergency:</b>					
1	1632		24	0.12 – 0.11A	
4	4035		47	0.22 – 0.21A	

**Luminaire is supplied with Battery plug/Socket disconnected, just prior to switching power on, connect battery plug and socket.**

Emergency versions – Emergency products with internal Ni-Cad battery packs in storage should be cycled charged/discharged/charged every 9 months, as per instructions below.

**Always disconnect battery plug and socket for storage.**

Any specific instructions concerning emergency luminaires must be complied with.

(Warning: Battery packs not cycled and stored for a year may not be recoverable).

Emergency products despatched from the factory are with the battery plug and socket disconnected.

See section **3.8.1** for further information.

## **1.0 Introduction - ACCLAIM Safe Area Recessible LED Luminaire**

The Acclaim Safe Area series is a recessible fluorescent luminaire with the facility of an integral battery back up for emergency use.

### **B15 SOLAS**

The luminaire can be installed to interface with fire resistant ceiling systems to maintain a B15 SOLAS fire rating; the integrity of the ceiling and insulation must be maintained using suitable insulation materials. The ceiling/fitting and insulation should be continuous (without any gaps), care must be taken to maintain this classification.

When insulated refer to Chalmit for Tamb ratings, as it affects life and battery performance. Normal operation is mains supply One LED strip on, Reducing output on one LED strip when on battery back up, local switching of the mains LED's, the emergency LED only being energised on mains failure.

**Important:** *This range is available in a number of similar but distinctly different versions. Care must be taken to use the correct instructions and spares, if in doubt contact Sales or Technical Department.*

## **2.0 Storage**

Luminaires are to be stored in cool dry conditions preventing ingress of moisture and condensation.

Any specific instructions concerning emergency luminaires must be complied with.

## **3.0 Installation and Safety**

### **3.1 General**

There are no health hazards associated with this product whilst in normal use. However, care should be exercised during the following operations.

Installation should be carried out in accordance with any applicable code of practice or regulations and fitting of specified insulating material is to be adhered to where a specific fire resistance rating is required. In the UK, the requirements of the "Health & Safety at Work Act 1974" and "Electricity at Work Regulations 1989" must be met. The luminaires are Class 1 and should be effectively earthed.

Application details on the rating plate must be verified against the requirements before installation.

The information in this leaflet is correct at the time of publication. The company reserves the right to make specification changes as required.

### **3.2 Tools**

12mm, 5mm and 3mm flat blade screwdriver, Pozi number 2 screwdriver

Suitable spanners for installing cable glands. Pliers, knife, wire strippers/cutters.

### **3.3 Electrical Supplies**

Luminaires fitted with electronic control gear are suitable for a rated supply between 220 and 240V, 50-60Hz, and for higher voltages to order. The safety limits are +10% of this. The supply would normally be expected to lie within +/-6% of rated. The LED supply is regulated, therefore the light output over the range is substantially unchanged.

Electronic gear has integrated power factor correction to >0.90.

**Warning:** Electronic control gear is assessed and/or tested for EMC requirements. This is based on the disposition of entry cables and, where appropriate, through wiring arrangements as supplied or specified. Users



must take care not to introduce wiring into parts of the apparatus materially different to that which could be reasonably inferred from the disposition of fixed supply terminals and specified through wiring.

### 3.4 Light Emitting Diodes (LED)

LED's are supplied in either 2000, 4000 Lumen options with the colour temperature of 4000K or 3000K.

### 3.5 Mounting

Luminaires should be installed where access for maintenance is practical and in accordance with any lighting design information provided for the installation. Where the luminaire is to be part of the ceiling construction, for aesthetic reasons, care is to be taken to ensure that the spacing and height specified by ceiling type is met. When mounting of ceiling support channels, via side arms, they must be secured onto channels by fixing screws. When B15 fire rating is a requirement, all conditions stated by the ceiling manufacturer and Chalmit must be met.

### 3.6 Cabling and Cable Glands

#### 3.6.1 Cables

The temperature conditions of the supply cable entry point are such that 70°C (ordinary PVC) cable can be used in all luminaires. 300/500 volts ratings are adequate. The selection of the cable size will be suitable for the fuse rating, which applies to the circuit on the supply side of the control gear. The standard maximum looping size is 2.5mm<sup>2</sup> with options of 6mm<sup>2</sup> or 4mm<sup>2</sup> through wiring. An external M6 earth stud is fitted adjacent to the cable gland.

#### 3.6.2 Cable Glands

Cable glands for entry into enclosures when fitted with any gland to body sealing method and the supply cable, must reliably maintain the IP rating of the enclosure. Two 21mm diameter holes are provided suitable for 20mm entries, one with a plug and seal suitable for permanent use, the other has a travelling plug. M20 entries are standard, other sizes are available on request. The clearance holes are powder coated so if required arrangements must be made to earth cable glands, kits are available and an external earth point is fitted as standard.

### 3.7 Electrical Connections

Access for the cabling is via removal of front cover and lamp tray. The front cover is secured using 6/10 off M5 captive screws, care to be taken as there is no suspension arrangement on this and the lampholder tray is secured by M5 screws and keyhole slots with suspension, allowing the tray to swing down, giving access to terminal blocks. Install the conductors in the appropriate terminals. Take care not to cut the conductor insulation excessively, 1mm of bare conductor outside the terminal throat is a maximum. Unused terminal screws should be tightened. Before re-fitting the Gear / LED tray and front cover, the cores/cable should be neatly tucked away and a final check made on correct connections. If switched operation is used, the bridge is removed or the common live connection separated.

#### 3.8.1 Installation

Following the mounting of the apparatus and the connection of the supply cable the unit **cannot** be insulation tested. When the unit is ready for operation the mains and the battery connections must be made.

#### 3.8.2 Commissioning

Energise the mains and check that LED's light when the supply is energised.

Emergency luminaires are supplied with the Battery plug/Socket disconnected. Just prior to switching power on, connect battery plug and socket.

Emergency luminaires will require battery packs to be cycled to obtain the full duration/capacity of the Ni-Cd battery cells. It is recommended that the unit is charged for a minimum period of 24 hours, then permitted to discharge via emergency operation (power OFF), and then charged again for a minimum period of 24 hours.

If checking battery duration at this time it may be necessary to repeat the cycle to obtain the full 3 hour duration.

### 3.8.3 Post Commissioning Storage

It is assumed that during commissioning the battery plug and socket are connected.

If the power is to be removed after commissioning for a period of time, our recommendations, along with guidance from the battery manufacturer, are:

- Up to 6 months – No action required. Mains power can be reapplied during this time and the battery will accept a charge.
- 6 to 12 months – Disconnect battery plug and socket to maintain charge in the battery. Before re-connection of mains power re-connect the battery plug and socket. Mains power can be reapplied and the battery will accept a charge.
- Longer than 12 months – Disconnect battery plug and socket. Approximately every 6 months carry out a charging/discharging cycle, 24 hours charging followed by 3 hour discharge and another 24 hour charge, then isolate power and disconnect battery plug & socket. This is to avoid deep discharge of cells, which is caused by a trickle discharge or by long term storage. This could lead to the cells not accepting a charge from the inverter or not achieving full expected duration.

### 3.9 Retro Fitting Lamps to LED's

Before opening the front cover ensure that the luminaire is isolated from the mains supply. Access for retro fitting is via the front cover, care is to be taken as there is limited suspension of the cover. Make sure that the correct ESD protection is taken during LED replacement to avoid electric discharge to the PCB.

### 4.0 Inspection and Maintenance

On battery models, we recommend that the battery duration is checked periodically.

#### 4.1 Replacement of Electronic Ballast and EM convertor Unit (*Where Fitted*)

The electronic ballast and EM convertor contain no replaceable parts. Should it be found necessary to replace these parts, the following procedure should be adopted:

Ensure that the luminaire is isolated from both mains and battery supplies, otherwise a risk of shock may occur. Disconnect the leads on the ballast at the terminal block. Undo the ballast securing screws and washers and withdraw the ballast from the gear body. Replace in reverse order. Replacement of the EM convertor is identical.

**Important:** *Isolate the mains supply and disconnect the battery terminal before carrying out any work.*

#### 4.2 Routine Examination

The luminaire must be de-energised before opening !

Individual organisations will have their own procedures, What follows are guidelines based on our experience :

- 1 Ensure lamps are lit when energised by mains supply and emergency lamp on battery pack.
- 2 Visually check cover front for damage, this should only be cleaned using a damp cloth, to avoid static, and only use recommended detergents for polycarbonates. If the polycarbonate is discoloured or damaged, a new cover assembly must be fitted. Additional prismatic diffuser or louvres should be cleaned with a dry cloth. If damaged, they should be replaced.
- 3 When de-energised and left to cool, there should be no significant sign of internal moisture. If there are any signs of water ingress, the luminaire should be opened up, dried and any likely ingress points eliminated by re-gasketting or other replacements.
- 4 Check cable gland for tightness and nip up if required.
- 5 Check any external and internal earths.
- 6 Check all terminations are firmly screwed down, tighten if necessary.
- 7 Check battery securing screws are tight, when fitted.
- 8 Check cover screw washers for wear and tightness of screws.
- 9 If it has been suspected that the luminaire has suffered mechanical damage, a stringent workshop check on all components should be made. All components can be removed from the luminaire for inspection.

**5.0 Disposal of Material**

The unit is made from combustible materials. The control gear contains plastic parts. All electrical components and the diffuser parts may give off noxious fumes if incinerated. Take care to render these fumes harmless or avoid inhalation. Any local regulations concerning disposal must be complied with. Any disposal must satisfy the requirements of the WEEE directive [2012/19/EU and Regulations 2012] and therefore must not be treated as commercial waste. The unit is mainly made from incombustible materials. The control gear contains plastic, resin and electronic components. All electrical components may give off noxious fumes if incinerated.

**5.1 LED's**

LED's in modest quantities are not "special waste". They should be broken up in a container to avoid injury. Avoid inhaling dust.

**Important:** *Do not incinerate LED's.*

**5.2 Battery Disposal**

Nickel cadmium batteries are defined as 'controlled waste' under the hazardous waste regulations and the disposer needs to observe a 'duty of care'.

Batteries can be returned to the manufacturers for re-cycling. They must be stored and transported safely and any necessary pollution control forms completed prior to transportation. Take care to fully discharge batteries before transporting or otherwise ensure that there can be no release of stored energy in transit. For further details refer to our Technical Department.



To comply with the Waste Electrical and Electronic Equipment directive 2012/19/EU and Regulations 2012 the apparatus cannot be classified as commercial waste and as such must be disposed of or recycled in such a manner as to reduce the environmental impact

**Chalmit Lighting is a leading supplier of Hazardous Area lighting products**

	<p><b>CHALMIT LIGHTING</b> PO Box 5575 Glasgow, G52 9AP Scotland</p>	
<p>Telephone: +44 (0) 141 882 5555 Fax: +44 (0) 141 883 3704 Email: info@chalmit.com Web: www.chalmit.com</p>	<p>Registered No: 669157 Registered Office: Cannon Place 78 Cannon Street London EC4N 6AF UK</p>	

**For technical support, please contact: techsupport@chalmit.com**

Note: Chalmit Lighting reserves the right to amend characteristics of our products and all data is for guidance only.



	<b>EU/UK-Declaration of conformity</b>		
	<b>UE-Déclaration de conformité</b>		
	<b>EU-Konformitätserklärung</b>		
Manufacturer	Chalmit	Address	388 Hillington Road, Glasgow. G52 4BL Scotland UK
Product	Acclaim Recessed Fluorescent Industrial		
Catalogue	ACLI/***/**/** Example: ACLI/218/BI/EM		
Area Classification	Industrial, (Non- Hazardous)		
Ingress Protection	IP54		
Ambient	-20°C to +45°C		
Terms of the directive:		Standard & Date Certified to	Standards Date Declared to
2014/30/EU Regulations 2016		Electromagnetic compatibility	EN 55015 : 2019
2014/30/UE		Compatibilité électromagnétique	EN 61547 : 2009
2014/30/EU		Elektromagnetische Verträglichkeit	EN 61000-3-2 : 2019
2014/35/EU Regulations 2016		Low voltage equipment	EN 60598-1 : 2015
2014/35/UE		Équipements électriques à bas voltage	EN 60598-2-5 : 2015
2014/35/EU		Niederspannungsgeräte / -systeme	EN 60598-2-22 : 2014
			EN 60529 : 1992+A2:2013
2012/19/EU Regulations 2012		Waste of electrical and electronic equipment	
2012/19/UE		Déchets d'équipements électriques et électroniques	
2012/19/EU		Entsorgung der elektrischen und elektronischen Geräte / Systeme	
2011/65/EU Regulations 2012		RoHS II Directive	

On behalf of the Chalmit, I declare that, on the date the equipment accompanied by this declaration is placed on the market, the equipment conforms to all technical and regulatory requirements of the above listed directives.

En tant que représentant du fabricant Chalmit, je déclare qu'à la date où les équipements accompagnant cette déclaration sont mis sur le marché, ceux-ci sont conformes à toutes les dispositions réglementaires et techniques des directives énumérées ci-dessus.

Hiermit bestätige ich, im Namen von Chalmit, dass am Tag der Lieferung des Produkts/der Produkte zusammen mit dieser Erklärung das Gerät/die Geräte alle technischen und regulativen Anforderungen der oben aufgeführten Direktiven erfüllt.

Name and Date      Mark Poutney    19/05/2021  
 Nom et Date  
 Name und Datum

Technical Manager  
 Directeur technique  
 Technischer Leiter

Quality Management System Accreditation:  
 Système de Management Qualité Accréditation:  
 Qualitätsmanagementsystem Akkreditierung:  
 Environmental Management System.  
 Système de gestion de l'environnement.  
 Umwelt kontroll system.  
**Certificate No./Certificat N°/Zertifikat Nr.**

**ISO 9001**

**ISO 14001**  
 by/par/durch  
**Lloyd's Register**  
**LRQ 4005876**